

VOLVO XC60



WE'RE VOLVO CARS.

We put people first.

We're Swedish. Scandinavian designers always start with the person who's going to use an object and ask, "What can we do to make this person's life better, easier or more comfortable?" We've always used this philosophy when we design our cars. So, while other car manufacturers might start with technology and try to squeeze people in around it, we begin by designing our cars around you. We ask what you need, and then use our technical skills to make your life easier, better, safer and more beautiful. Form follows function, and when you design a car inside and out with people in mind, it looks naturally beautiful. We think that looking at and interacting with our cars should make you feel great, every day. Designing cars around people has led to many innovations over our

88-year history. You know the three-point safety belt in your current car? That was our invention from 1959. And now we're working towards our vision to design cars that should not crash. In the shorter perspective, our aim is that by 2020 nobody should be killed or seriously injured in a new Volvo. Of course, you'll already benefit from this research in your current Volvo. We've addressed a few environmental issues, too – in 1976, we developed the lambda sond – a sensor that monitors exhaust gas, reducing emissions and boosting performance as well as economy. It's still part of every petrol-engined car in the world. Innovation is at the core of Volvo Cars – it's because of where we come from.





If you're looking for a premium SUV which combines refinement with capability, the Volvo XC60 is for you. Whether you go about your city life or whether you're off on a break out of town, this is the SUV to do it in. Not only does it offer you the practical appeal of a commanding driving position, all-weather capability and versatile functionality, its Scandinavian design also make it a suitably distinguished companion for a night at the opera.

At the heart of the dynamic, natural driving experience is a great chassis. We're proud of the standard Dynamic chassis, and we've heightened its responsive, in-command driving experience.

And as soon as you get behind the wheel, you'll discover another great example of Scandinavian design around people. Seats have been a Volvo strength since the 1970s, when we enlisted ergonomic experts to help us develop a supportive shape that ensures you arrive fresh and relaxed after even the longest

journey. With the XC60, we've been able to retain the comfort but make the seats even sportier, as befits a true driver's car. Then, there's the sheer build quality. You can always tell true craftsmanship by looking at the details. The XC60 has beautifully styled integrated tailpipes, which are the physical and visual link to our technically advanced, highly efficient new generation of powertrains.

A refined and dynamic SUV also needs to have impact. With its strong shoulders and V-shaped bonnet, it's unmistakably a Volvo and carries itself with pride. The wide grille seems ready to devour the road ahead, while the expressive headlights appear as if they've been shaped by the wind at high speed. These dynamic design cues dovetail beautifully with elements emphasising the height and stature: in the front, the striking vertical daytime running lights, and in the rear, the elegant vertical light cluster, which has become an iconic Volvo signature in its own right.

"It's the perfect car for demanding drivers in search of refinement and freedom – both in town and beyond the city limits."

VOLVO XC60

Meet the SUV that's great to drive.

Your lifestyle says you need an SUV; your heart says you want a stylish, driver-focused road car. If this is your dilemma, we've designed the Volvo XC60 as your solution. It's the perfect car for demanding drivers in search of refinement and freedom – both in town and beyond the city limits.

You really have to drive an XC60 to appreciate its superb handling. Thanks to its class-leading chassis and Corner Traction Control, a system that makes cornering even more fun, it doesn't feel like a towering, top-heavy SUV: it's every bit as nimble and agile as a ground-hugging road car.

At the same time, its ride height gives you a commanding driving position when negotiating busy city traffic, for which the perfectly proportioned XC60 is ideally suited. And it's reassuring to know that when the temperature drops, your XC60 is built to take adverse conditions in its stride.



We Swedes like to think we're
too nice to judge things on their looks.
We're not.

"I was inspired by a river near my home," explains the exterior design manager Steve Potter. "The water was flowing incredibly fast over the rocks. We set about creating this visual tension and constant movement, which changes depending on your point of view – it's alive. The result is a very human, organic feel." Our XC60 gets a smarter, more purposeful look that's as much at home on a city street as on a country lane. We've refined the

design so the car is now all one body colour, which gives our SUV a more urban twist. The new headlamps give the XC60 a focused, determined face with huge road presence, and the intense vertical daytime running lights are positioned far out to the corners of the car to emphasise the height and stature. True to our Scandinavian design principles, we've worked on every last element to reduce

what our designers call visual "noise". We care about small details like moving the washer nozzles out of sight and masking anything that might detract from the elegant, clean surfaces. The strong shoulders are another Volvo design cue – as is the grille with the iconic Volvo diagonal. Together, they tell the world that this car is proud to be a Volvo.



*"We're famous for our seats
– they're a proud tradition for us at Volvo Cars."*

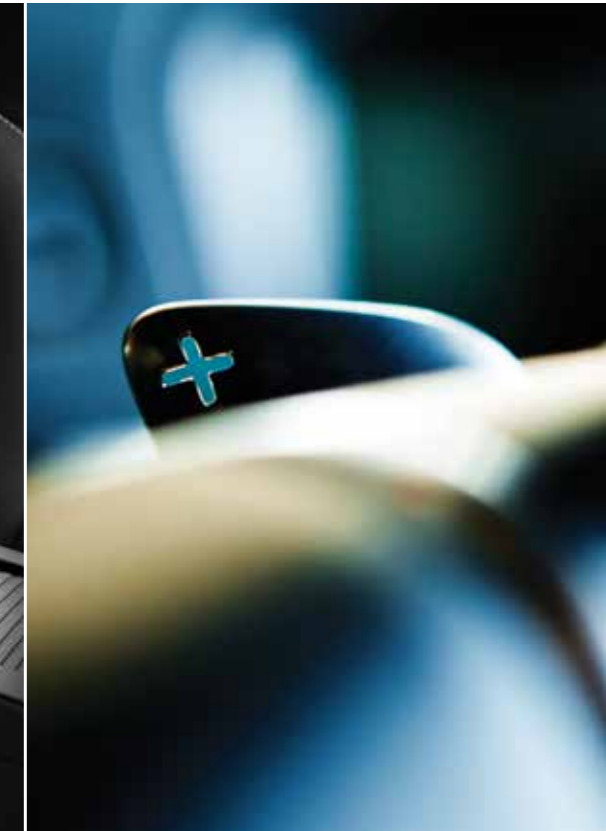

We've designed the cockpit around you, the driver. Get inside and feel in complete command as the dashboard gently angles towards you. We were inspired by high-performance motorbikes when we came up with the idea of a single round instrument flanked by two smaller dials. Then, we carefully sculpted the three-spoke steering with the aim of giving you a very physical sense of connection between your car and the road. But where you sit is even more important. "We're famous for our seats," says Stefan Sällqvist, "they're another proud tradition for us at Volvo Cars. Our sport seats look

fantastic and, true to our unrelenting commitment to ergonomic design, you'll be able to drive for hours sitting in them without getting tired. It also has great side support all the way from your thighs to your shoulders, so the seats keep you firmly in position even when you're cornering fast." And because it's a Volvo, we designed the seats so your passengers will enjoy the ride too. Everybody travels first class, and with our two-stage integrated booster cushions, children over 3–4 years will ride safely in comfort while seated at the right position.

No need to take your hands off your steering wheel as you shift up and down the automatic gearbox in manual mode – just flick through the gears with our optional gearshift paddles. You'll be in total command of your car, with both hands on the wheel. And quicker gear changes give your drive an additional edge when you're in the mood for upping the tempo.

*"Think of the XC60 like a coat
– just a very stylish and practical one."*

ALL THE BEST PLACES ARE TOUGH TO GET TO.

See you there, then.

In Sweden, we say there's no such thing as bad weather, just the wrong clothes. We think that applies to cars, too. We've always designed our cars to incorporate the latest driving technology so you can go anywhere regardless of what the weather is throwing your way. Think of our cars like a coat – just

a very stylish and practical one. Choose the All-Wheel Drive variant, and your XC60 will be unfazed by any kind of weather, even if roads are poor. Hill Descent Control boosts that capability even further, making the XC60 a true all-round vehicle. On the motorway and twisty country lanes, the

overall impression is one of powerful agility and assurance. We have a standard Dynamic chassis, which we've spent thousands of hours tuning for a responsive, in-command driving experience. And for an all-out sporty ride, there's our stiffened sport chassis.



*"Our vision is to design cars
that should not crash."*

INTELLISAFE

*Intuitive safety by Volvo Cars.
For you, and for those around you.*

At Volvo Cars, safety is an intrinsic part of our DNA. We've invented some of the world's most pioneering life-saving technologies – such as the three-point safety belt that's been acknowledged one of the most important innovations of mankind.

But we aim higher. Our vision is to design cars that should not crash. In the shorter perspective the aim is that by 2020 nobody should be killed or seriously injured in a new Volvo.

IntelliSafe is our approach for a more harmonious relationship between cars and people. To achieve this, we have infused your Volvo with smart, intuitive innovations for a safer drive. And the IntelliSafe technologies help protect not only the people inside your car – we also consider people on the outside, for example with technology that helps you to detect pedestrians and cyclists.

When you drive at speeds up to 50 km/h, our City Safety collision avoidance technology

looks ahead of you and brakes automatically if you're about to run into a vehicle in front. And because we know you love to drive, our active IntelliSafe technologies like Electronic Stability Control add to reassuring driving stability in all conditions without sacrificing the joy of driving. It's simply about giving you the most human driving experience, on your terms. And helping keep people out of harm's way, whether they happen to be inside or outside your car.

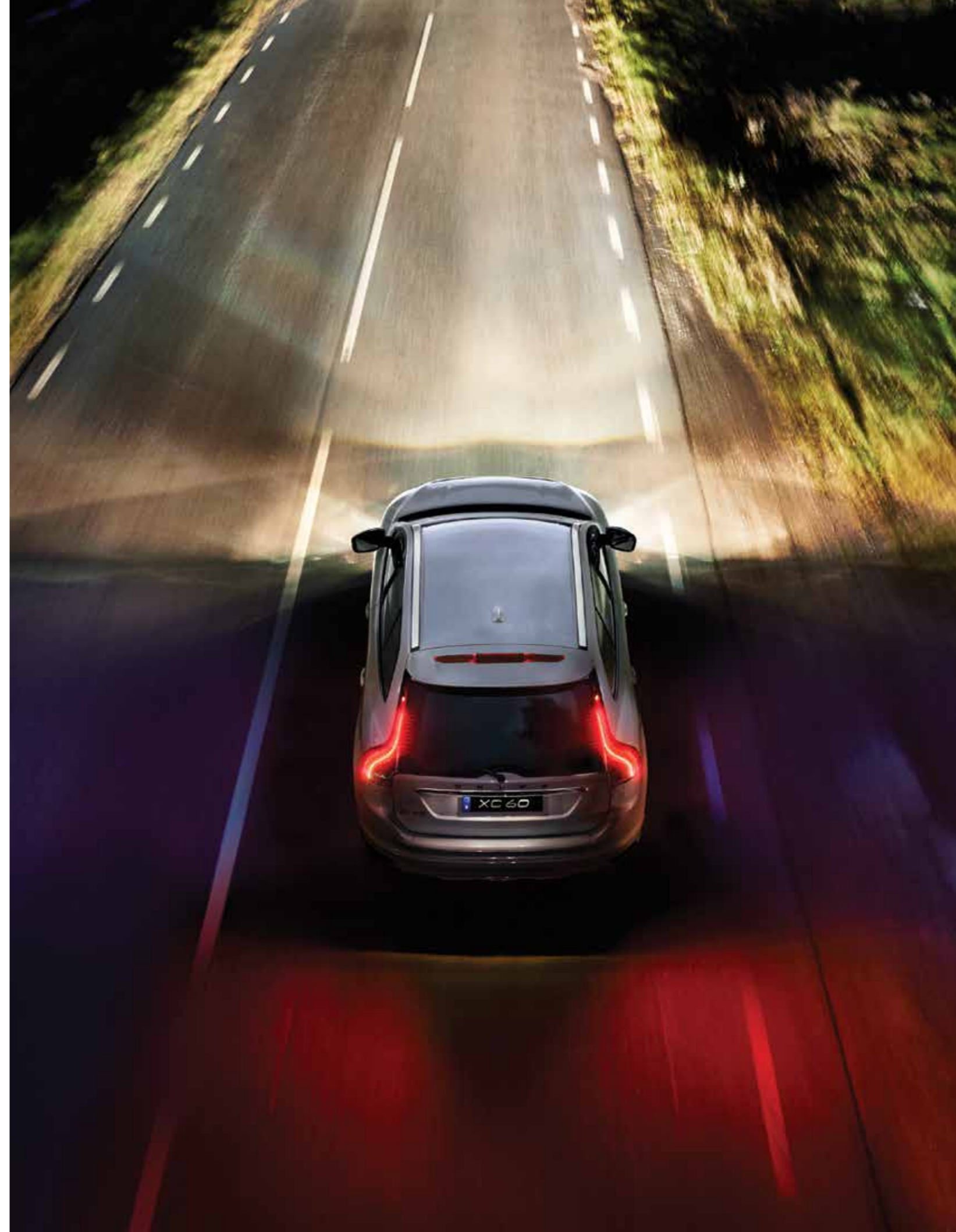

INTELLISAFE



In town, City Safety is designed to prevent you from colliding with the car in front if it stops, or slows suddenly. This advanced IntelliSafe system will automatically brake to avoid a crash and works at speeds of up to 50 km/h - an accident can be avoided at a speed difference of up to 15 km/h to the vehicle in front.



The Volvo XC60 is available in a wide range of cutting-edge diesel engines designed to meet your preferences. All of them are designed to offer maximum driving pleasure while using fuel efficiently and keeping CO₂ emissions at a minimum.



RDESIGN



Would you like to enhance the dynamic personality of your XC60 even further? Well then, R-Design is for you, with a range of features to give your Volvo a sporty, unique profile.

But R-Design is so much more than a cosmetic exercise – as with the all best Scandinavian design, form follows function. An R-Design XC60 benefits from a stiffer sport chassis and more direct steering, all of which means you enjoy getting to your adventure even more.

Mirror caps and window frames in silver metallic finish and the unique front diffuser are a subtle reminder that your R-Design is out of the ordinary.



RDESIGN

“Our R-Design Sport chassis has been lowered and stiffened for even better cornering – meaning you’ll enjoy the thrill of driving your XC60 even more.”



For an exterior with a more individual, sporty look, R-Design offers gorgeously sculpted alloy wheels and unique door mirror covers in silver metallic. At the back, a motorsport-style diffuser enhances your car’s dynamic presence, while the R-Design chrome dual exhaust pipes add the perfect finishing touch to the exterior of your XC60.

The R-Design story continues in the interior, starting with supportive sport seats in leather. Also included is an exclusive R-Design steering wheel as well as sport pedals. A gear shifter gaiter with contrasting stitching, our unique blue R-Design digital driver display, interior LED lighting and a striking Inscription charcoal headliner all add to the R-Design experience.

The exterior colour you choose has a dramatic impact on the personality of your Volvo. But no matter which you choose, each one imbues the car with a sense of luxury and presence.

“Our colour palette is very Scandinavian,” says Ebba Maria Thunberg, who is responsible for colours and material. “When you look at our

palette, you'll find that it contains softer tones that are more connected with nature, with a few bold splashes.” Being Swedish, our designers are inspired by the ocean and the sky, but also by the shore and the way the light changes throughout the seasons. Every tone speaks of uniqueness, quality and charisma.



717 Onyx Black Metallic



700 Twilight Bronze Metallic



707 Inscription Crystal White Pearl



711 Bright Silver Metallic



712 Rich Java Metallic



467 Magic Blue Pearl



492 Savile Grey Metallic



714 Osmium Grey



Sport seat



Comfort seat

INLAYS

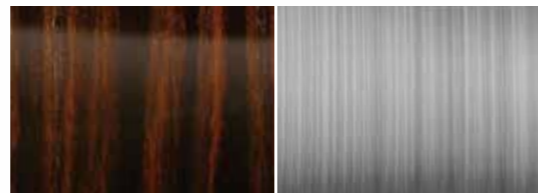

Urbane Wood

Shimmer Graphite Aluminium



R-Design



Leather

Sport Leather

R-Design Leather



From expressive to discreet, elegant to sporty, you can give your XC60 a unique twist by the wheels you choose.

Would you like to make an entrance or do you prefer the charm of the understated? Are you going for a sporty persona or an intricate, refined look? Try different wheels on our online configurator and find the one that's right for you.

Lesath, 7.5x19"
Diamond Cut/Matte Tech Black

ACCESSORIES



Candor, 8x20"
Diamond Cut/Matte Black or
Diamond Cut/Matte Iron Stone



Inscription Avior, 8x20"
Silver Bright



Titania, 8x20"
Diamond Cut/Glossy Black



Talitha, 8x20"
Diamond Cut/Matte Silver Stone or
Diamond Cut/Matte Dark Grey or
Diamond Cut/Glossy Black



Leda, 7.5x18"
Diamond Cut/Light Light Grey



Pan, 7.5x18"
Silver Bright



Freja, 8x18"
Diamond Cut/Light Light Grey



Ixion II, 8x20"
Diamond Cut/Matte Black
(R-Design)

Your XC60 is your
home away from home.
Give it your signature.

Choose the XC60 and you'll enjoy an elegantly designed cabin as standard, with a superior finish in evidence everywhere you look – from the silk metal finish on our air vents to the fine cloth surfaces on the door pillars. Our seats come in premium quality leather

giving you legendary Volvo comfort while also keeping you firmly in place in those fast corners. Choose our heated three-spoke steering wheel and you can gently warm your hands in cold conditions. There's an easy-to-read analogue driver display or

if you prefer, try our new digital driver display. Our Inscription offer consists of a palette of luxurious options, which you can combine in your own way, giving you the opportunity to truly design your car around your own taste.



"Our Park Assist Camera, front blind view allows you to 'see around corners' as you negotiate tight exits."

NO TWO LIVES ARE THE SAME. *Make sure your Volvo matches yours.*

The most pleasurable part of buying a new Volvo is putting your personal stamp on it. You can do that by choosing accessories that reflect your own taste and that cater to your particular lifestyle.

There's nothing more challenging than trying to negotiate tight exits and junctions with restricted visibility. Our Park Assist Camera, front blind view, takes the stress out of these situations. It allows you to "see around corners" with a 180° field of vision to the left and right in front of you. The image is projected onto your seven-inch centre display so you know exactly who, or what, is approaching.

Our Park Assist Camera, rear does the same job when you reverse. It's mounted in the boot lid and dramatically increases your field of vision behind the car. The image is

projected onto your centre display, so you can spot any low obstructions when manoeuvring. There's also a zoom-in view you can use to hitch up a trailer to your towbar. It's so good, you might even start to enjoy the situations you used to dread.

Since there can only be one driver at a time, the XC60 also offers some premium amusements for your rear seat passengers. Our Rear Seat Entertainment system with 8-inch touchscreens and integrated DVD players can operate independently. Wireless headphones are standard (you can also plug in your own wired headphones), so one's game doesn't fight with another one's movie. For your children, we have three Volvo Cars-approved child seats available. Infants of up to one year (or 13kg) travel safely in our rear-facing infant seat. Side wings give

protection in a side impact, and you can easily adjust the padded headrest and five-point harness. There's a canopy to block the sun, too. This infant seat is also easy to carry and can be used as a carrycot.

Our convertible child seat is suitable for children aged nine months to six years (or 9–25kg). It's fitted using the car's safety belt and is easily adjusted to help optimise comfort and safety.

Finally, our booster seat helps position children weighing 15–36kg at the correct height for the safety belt and is designed to optimise side impact protection. The headrest and width adjust easily to enhance comfort, and the backrest can be reclined when your child wants to rest.



To reinforce your XC60's dynamic stance, you can customise it with our Exterior Styling Accessories, which are available in Matte Silver or Iron Stone finish.

Our eye-catching front bumper bar gives your XC60 an even more purposeful look, with a metallic finish that's beautifully accentuated as it catches the light. The integrated running boards emphasise the sleek lines, visually connecting it close to the road. And the rear skid plates with beautifully sculpted double integrated tailpipes boldly underline the dynamic character.

The wheels are the jewels of your car. Our gorgeous 20", Diamond-Cut Candor alloy wheels feature a six-spoke design in Matte Black or Matte Iron Stone finish, making sure your entrance doesn't go unnoticed.



“With the dog gate, you can open the tailgate without your dog leaping out – which makes life so much easier.”



No matter what you like to do in your spare time, there's a pack & load accessory for you. Our exclusive, aerodynamic Space Design roof box looks great, is voluminous and offers minimal wind resistance. It can be opened from both sides and is available in Titan Silver or Black, as well as two sizes: 320 or 430 litres, with a maximum load of 75kg.



If you carry large sports equipment, our roof load carriers are essential. Fitted directly onto your car's roof rails, these aerodynamically designed aluminium load carriers provide an easy-to-use rooftop carrying system which you can then combine with our other pack & load accessories, such as our skiholder, roof-mounted bicycle holder or our Space Design roof box.

For the load compartment in the rear, there's our steel safety grille, which is an alternative to the standard safety net. This gas-sprung steel grille is colour-coordinated with your interior and helps protect you and your passengers from unsecured loads when

braking sharply. And when you don't need it, it folds conveniently up against the roof. Our load compartment divider is another great accessory. Used together with the steel safety grille, this divides the load compartment into two sections – convenient if you want to carry your dog and luggage, or to separate grimy or fragile cargo from other cargo. Finally, to give your pet a place of its own, you can complement the safety grille and load compartment divider with our dog gate. It allows you to open the tailgate without your dog leaping out – which makes life so much easier.



The simplest way to own a car.

We love it when you're happy. When things are easier than you expect, or go faster and become better. Because when you buy a Volvo, you buy the simplest way to have a car. Financing, insurance, servicing, changing tyres, cleaning – those aspects of car ownership that you might not find very interesting, are the ones that we love to make easier and better for you. That's why your

Volvo Car dealer will always offer you a whole range of simplifying services and offers all designed around you, giving you the most carefree ownership experience possible. Still, this is just the beginning. Through our uniquely Swedish approach to innovation, we continuously find new ways to make your life simpler. For instance, the Connected Service Booking function, which lets you book an

appointment just by pushing a button in your car. Or the new way of working in teams – like in a racing pit-stop – that is gradually being introduced in Volvo Car workshops all over the world. We call it Volvo Personal Service and it will make your workshop visits much shorter and more convenient. In the future, servicing your car will be so much simpler.

BUYING & OWNING

- Extended Warranties
- Financing
- Insurance
- Service Contract
- My Volvo Website

MAINTENANCE & SERVICES

- Volvo Genuine Service
- Volvo Professional Car Care
- Tyre Services

IF SOMETHING HAPPENS

- Volvo Assistance
- Repairs
- Volvo Glass Services
- Volvo Dent Repair
- Car Climate Services

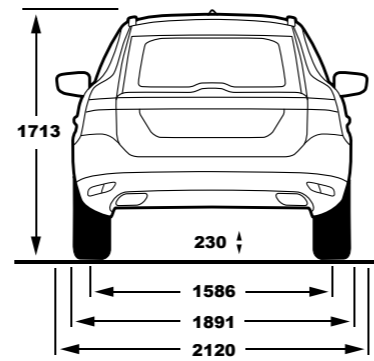
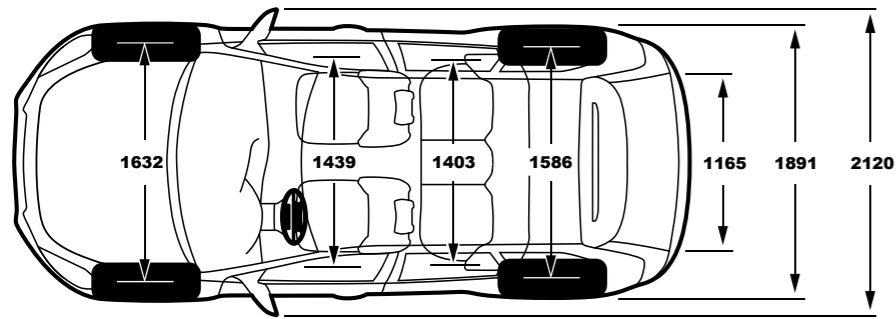
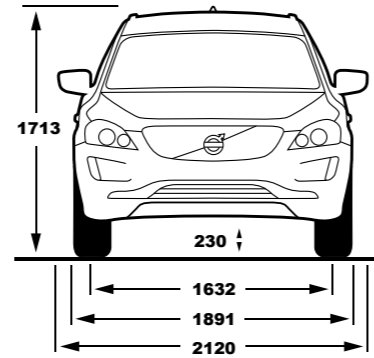
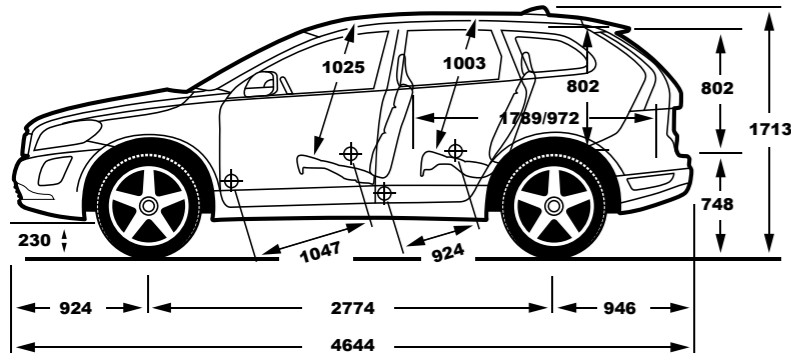

Please note: Some of the information in this brochure may be incorrect due to changes in product specifications that may have occurred since printing. Some of the equipment described or shown may now only be available at extra cost. Before ordering, please ask your Volvo Car dealer for the latest information. The manufacturer reserves the right to make changes at any time and without notice to prices, colours, materials, specifications and models.



V O L V O